



TYPICAL

YSC-8330

USER MANUAL

XI'AN TYPICAL INDUSTRIES CO.,LTD.

1	Notice	3
	1.1 Work environment	3
	1.2 Notice of installation	3
	1.3 Notice of safety	3
2	Installation and Adjustment	4
	2.1 Controll box	4
	2.2 Speed controller	4
	2.3 Speed controller bracket (direct-driven)	4
	2.4 Identifier	4
	2.5 Servo motor (direct-driven)	4
	2.6 Servo motor (belt-driven)	5
	2.7 Magnetic synchronizer	5
	2.8 Installation diagram of system	5
3	Power Connection	6
	3.1 Single phase 220V power connection	6
	3.2 Three phase 380V power connection	6
4	Connector Diagram	7
5	Function of Frant Panel	8
6	Function of Operation Box	8
7	Operation of the Normal Function Interface	10
	7.1 Parameter setup	10
	7.2 Parameter solidifying	11
	7.3 Resumine parameter through One-Key Default	11
	7.4 Access the special function parameter interface	11
	7.5 Function of identifier	11
	7.6 Adjust the tacking	12
	7.7 Slow start function	12
	7.8 Resume the default value of all parameters	13
	7.9 Encrypt the parameter interface	13
	7.10 Function of Machine LED	13
8	Operation of the Special Function Interface	13
	8.1 Dynamic speed limitation	13
	8.2 Counting the product quantity	13
	8.3 Stitch length	13

8.4	Different ratio	14
8.5	Actual speed display	14
8.6	Stitches statistic	14
8.7	Current time of power-on	14
8.8	Total time of power-on	14
8.9	Total idle time	14
8.10	Total working time	14
8.11	Using efficiency	14
9	General Parameter Table (part)	15
9.1	Speed parameter	15
9.2	Time parameter	15
9.3	Enable parameter	16
9.4	Degree parameter	18
9.5	Special function parameter	19
10	Measurement of Error and Warning	20
11	Signal Checking	20
12	Review the History Errors	23
	Appendix I: 7-segment Display Characters Compare Table	24
	Appendix II: How to adjust the speed controller	25
	Appendix III: How to update the control box with the update module	26

1. Notice

YSC-8330 is used in system of industry sewing machine. For perfect operation and safety, installation and operation must be supervised by professional.

1.1 Work environment

- ▲ Please use 220V AC in $\pm 10\%$ ranges.
- ▲ To avoid the false operate, please keep the product away from the high electromagnetic interference.
- ▲ Please operate in the area which temperature is $5^{\circ}\text{C}\sim 45^{\circ}\text{C}$.
- ▲ Please operate in the area which humidity is 80% or less.
- ▲ Please keep the product away from the flammability and exploder.

1.2 Notice of installation

- ▲ The control box should be installed correctly follow the instruction in this manual.
- ▲ Turn off the power and unplug the cord before installation.
- ▲ The wire must not set to be near the wheel and other movable parts.
- ▲ To avoid the static interference and current leakage, all grounding must be done.

1.3 Notice of safety

- ▲ Turn off the power before maintenance and repairs or raising the machine arms, or changing needle, or threading needle.
- ▲ Please don't open the box except the professional.
- ▲ When turn on the machine in the first time, use low speed to operate and check the correct rotation direction.
- ▲ During machine operation, don't touch any moving parts.
- ▲ All moving parts must use the protective device to avoid the body contact and objects insertion.
- ▲ When there is water or other liquid, or caustic material on box or motor, you must stop operation and turn off the power.
- ▲ All connector shouldn't be plug and unplug when power on.
- ▲ The connector should be plug and unplug in the correct method.

2. Installation and Adjustment

2.1 Control box

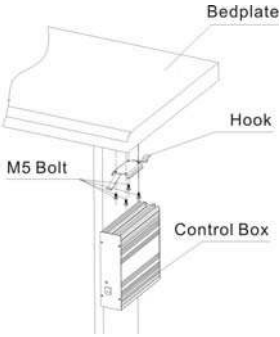

Install the hook on bedplate with 4 M5 bolts.

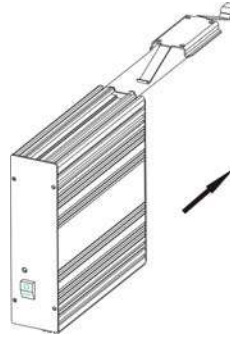

Install control box.

2.2 Speed controller

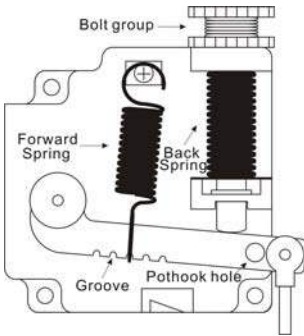

2.3 Dimension of speed controller bracket (direct-driven)

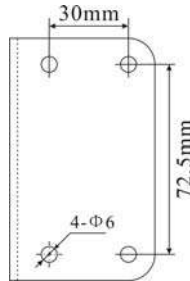

2.4 Identifier bracket (direct-driven)

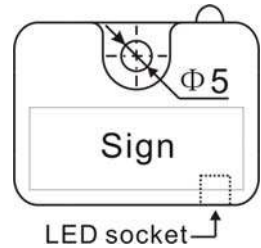

2.5 Dimension of servo motor (direct-driven)

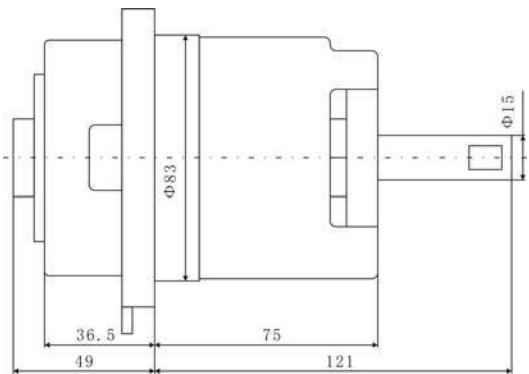
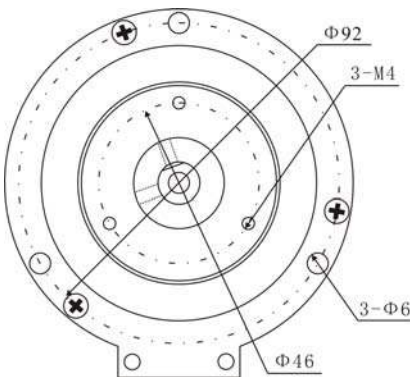

2.6 Dimension of servo motor (belt-driven)

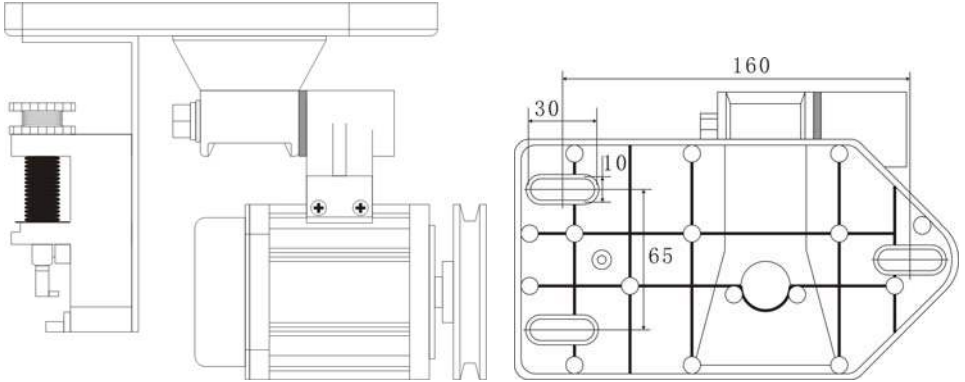

2.7 Magnetic synchronizer

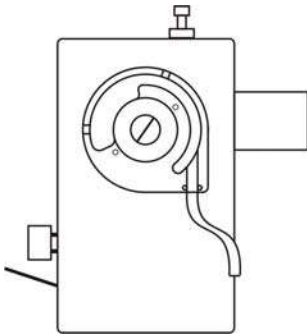

When install the wheel, the first hole must be vertical to the plane of the main axis.

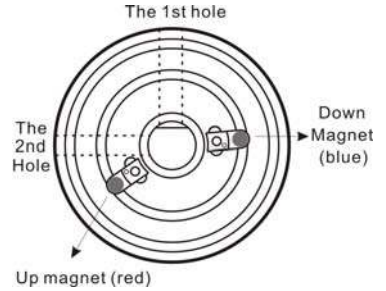

2.8 Installation diagram of system

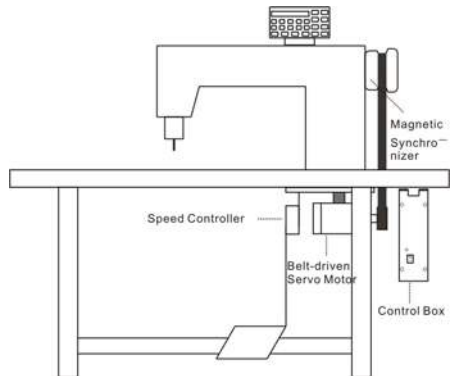
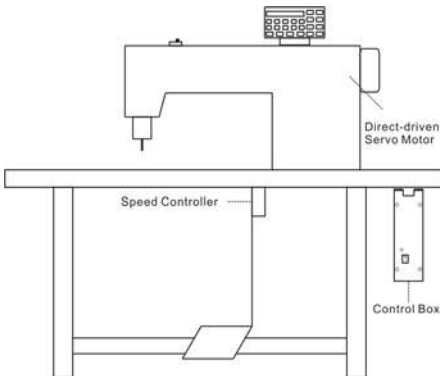

3. Power Connection

3.1 Single phase 220V power connection

Ground wire (green & yellow) must be grounding.

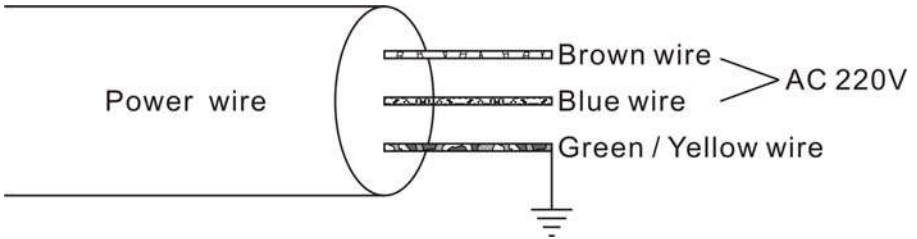

3.2 Three phase 380V power connection

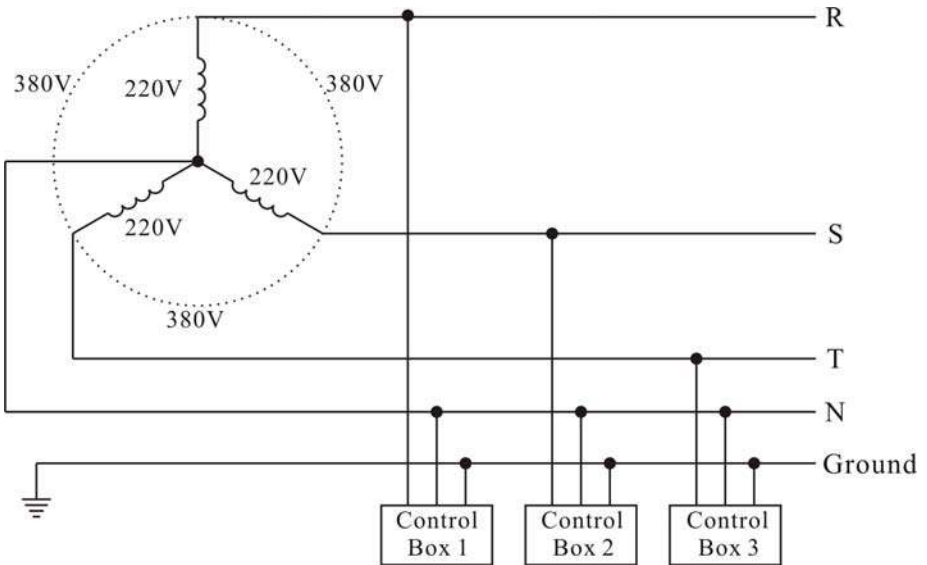

4. Connector Diagram

220V AC

AC POWER	
1	Null Line
2	Live Line
3	Ground

(M)

MOTOR	
1	A Phase
2	GROUND
3	B Phase
4	C Phase

(M)

ENCODER	
1	--
2	QEB
3	W Hall
4	U Hall
5	+5V
6	UP
7	QEA
8	V Hall
9	GND
10	--

(M)

IDENTIFIER	
1	SDA
2	--
3	SCL
4	--
5	GND
6	+5V

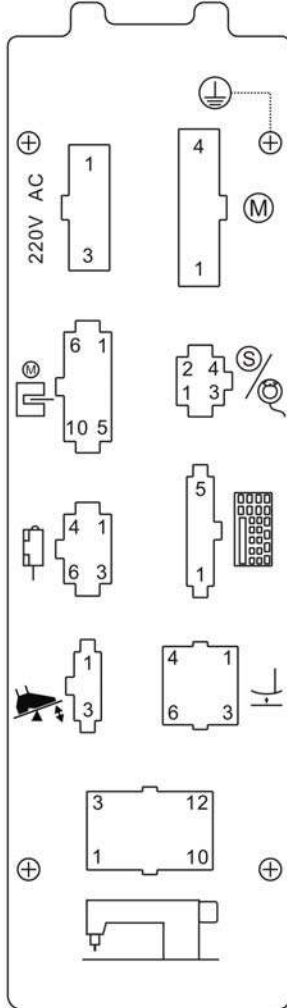

(S)

SPEED CONTROLLER	
1	+5V
2	GND
3	OUTPUT

(S)

SAFETY SW.	
1	--
2	OV
3	--
4	SAFETY SW.

(M)

INSPECTOR	
1	Up
2	GND
3	+5V
4	Down

(M)

OPERATION BOX	
1	+5V
2	CANH
3	--
4	CANL
5	GND

(M)

FOOT LIFTER	
1	+31V
2	--
3	--
4	Foot SOL.
5	--
6	GROUND

(MP)

(M)

SEWING MACHINE	
1	LED
2	+5V
3	GROUND
4	+31V
5	Trimmer SOL. (MT)
6	COR. SW.
7	+31V
8	Wiper SOL. (MW)
9	REV. SW.
10	+31V
11	REV. SOL. (MR)
12	GND

Attention: (S) for direct-driven is safety SW., and for belt-driven is Synchronizer.



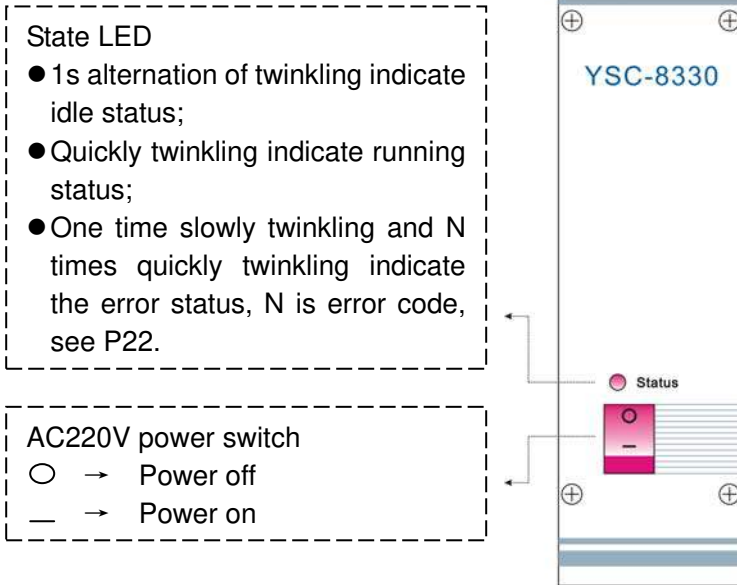



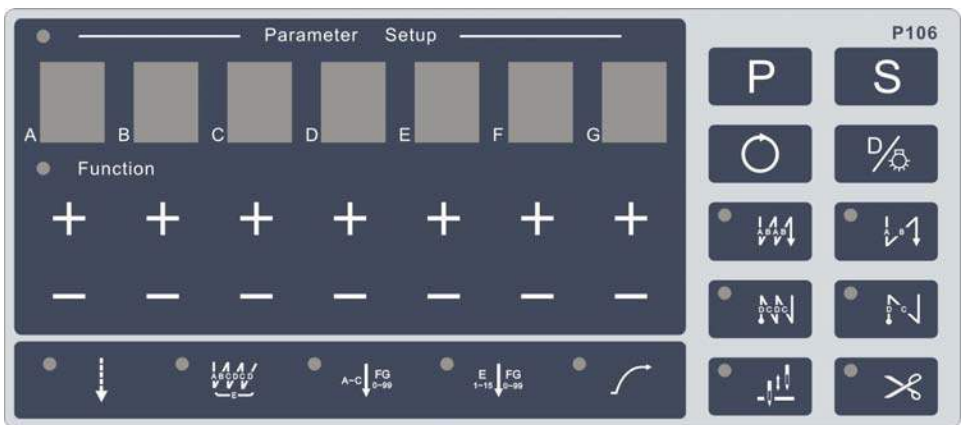

5. Function of Front Panel











6. Function of Operation Box

P106 operation box diagram (P104 can also be used for YSC-8330)



Function	Key	Operation
Start Tacking Selection		Double start tacking, A is the stitches of forth sewing; B is the stitches of back sewing. They are both in range 1~15.
		Single start tacking, A is the stitches of forth sewing; B is the stitches of back sewing. They are both in range 1~15.
End Tacking Selection		Double end tacking, C is the stitches of back sewing; D is the stitches of forth sewing. They are both in range 1~15.
		Single end tacking, C is the stitches of back sewing; D is the stitches of forth sewing. They are both in range 1~15.
Free Sewing		<p>▲ As the pedal is stepped forward, the start tacking(if selected) will be done automatically, then machine will start normal sewing. Once the pedal returned to balance, machine will stop immediately.</p> <p>▲ As the pedal stepped backward, the end tacking, trimming and wiping(if selected) will be done automatically.</p>
Bar Tacking Sewing		<p>▲ Once the pedal is stepped forward, all the seams of bar tacking, A, B, C, D sections will be completed with E times, and the trimming will be done automatically.</p> <p>▲ The pedal must be returned to balance for next sewing.</p>
Single Constant-Stitch Sewing		<p>▲ Once the pedal is stepped forward, F, G stitches will be completed.</p> <p>▲ Three mode (A, B or C) could be selected.</p>
Multi Constant-Stitch Sewing		<p>▲ Once the pedal is stepped forward, F, G stitches will be completed with E times.</p> <p>▲ Constant-Stitch Sewing will perform the</p>

		number of segments and times as setting, when the stitches are zero, machine will stop immediately.
Slow Start		Slow start switch, see 7.7.
Needle Up / Needle Down		Select the stop position of needle.
Trimming Enable		Enable or disable the trimming.
Parameter Function		Enter or exit parameter function interface.
Setup Function		Confirm and save current value of parameter.
Interface Selection		Switch current interface to another.
One-Key Default / Lighting LED		See 7.3 and 7.10.
Increase		Value increase.
Decrease		Value decrease.

7. Operation of the Normal Function Interface

The following operation could be valuable if normal function interface LED is on, other interface could be entered though .

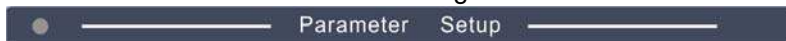

7.1 Parameter setup

Press  will be into parameter interface, using **E+** and **E-** to select parameter type, using **F+**, **F-**, **G+** and **G-** to select parameter index, value of current parameter will be displayed on bar A~D, using increase and decrease key can modify the value, as follow:

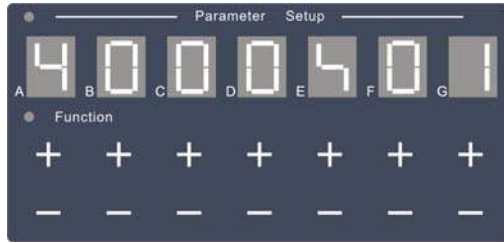

For example, the value of **S01** is 4000. The bar will be twinkling if modified, use **S** to confirm or **P** repeat change. After modifying, use **P** to back to sewing interface.

7.2 Parameter solidifying

If users want to change some parameter's default value, then select the parameter, press **O** maintain a moment, after "SD OK" displaying, the default value has been changed.

7.3 Resume parameter through One-Key Default

Select any parameter in parameter interface, **%** can be used to recall the default value. The bar will be twinkling if modified, use **S** to confirm or **P** repeat change.

7.4 Access the special function parameter interface

Without any operation during power up, only S, T and A type parameter can be select. Press **P** during power up will display "O EN", and then O type parameter can be accessed.

7.5 Function of identifier

The machine type code (**O03**) is associated with identifier automatically, the parameter relative would refresh according to machine type. If any wrong be with the identifier, it can be disabled and set by manual, as below:

- ▲ Press **B+** during power up, "ID D" would be displayed then the identifier is disabled;
- ▲ Set **O03** to according with machine type;
- ▲ Set **O30** to be "ON" will re-enable the identifier function.

The default value of some parameters are different from machine type, as below:

Default Code	S01	S03	S04	S05	S06	T01	T02	A05	O20		
01	4000	2000	2000	2000	3000	42	45	OFF	ON		
02	3000	1800	1800	1800	2000	53	48	OFF	ON		
05	3500	1800	1800	1800	3000	42	45	OFF	ON		
06	2500	1500	1500	1500	2000	59	57	OFF	ON		
07	4000	2000	2000	2000	3000	41	36	ON	OFF		
08	3000	1800	1800	1800	2000	59	45	ON	OFF		
10A	4000	2000	2000	2000	3000	41	36	OFF	OFF		
11A	3000	1800	1800	1800	2000	59	45	OFF	OFF		
12	3500	1800	1800	1800	2000	45	31	OFF	OFF		
14	3500	1800	1800	1800	2000	57	46	OFF	OFF		

7.6 Adjust the tacking

7.6.1 Adjusting of RVE. SOL. action time

For start/end tacking or bar tacking, if unbalanced situation is appeared during natural direction to reverse direction, please correct it as below:



7.6.2 Adjusting of RVE. SOL. release time

For start/end tacking or bar tacking, if unbalanced situation is appeared during reverse direction to natural direction, please correct it as below:



7.7 Slow start function

If  be effective, every new operation after trimming will run by slow speed for several stitches firstly, speed is relative with parameter **S08**, stitch is relative with parameter **O01**.

7.8 Resume the default value of all parameters

Set parameter **O17** to “ON”, turn on the power again, after twinkling of “INIT” finished, all parameters have been default value themselves.

7.9 Encrypt the parameter interface

First change parameter **O27** for user’s password, then set parameter **O15** “ON” to enable password, after this, accessing to parameter interface will be in password interface firstly, set the correct password and use **S** to confirm.

7.10 Function of Machine LED

The lightness of LED can be set by **%** in sewing interface, the lightness increase 20% each press, if 100% already, turn to 0%, and so on.

8. Operation of the Special Function Interface

Press **○** could be access special function interface from normal function interface, showed as below:



Bar A and B according to SN of function, bar D~G display parameter, press **B+** and **B-** to select function:

8.1 Dynamic speed limitation



SN F1, display current speed up limitation, could be change during running.

8.2 Counting the product quantity



SN F2, display the product quantity, increase for 1 after trimming.

8.3 Stitch length



SN F3, according to actual stitch length.

8.4 Different ratio



SN F4, while using puller, display the different ratio for stitch length.

8.5 Actual speed display

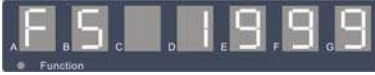

SN F5, display the actual speed.

8.6 Stitches statistic



SN F6, display the stitches statistic of each working procedure.

8.7 Current time of power-on



SN F7, for example, current time of power-on is 6 hours and 13 minutes.

8.8 Total time of power-on



SN F8, for example, total time of power-on is 130.8 day.

8.9 Total idle time



SN F9, for example, total idle time of power-on is 12.5 day.

8.10 Total working time



SN FA, for example, total working time of power-on is 118.3 day.

8.11 Using efficiency



SN FB, for example, current using efficiency is 90.4%.

9. General Parameter Table (part)

9.1 Speed parameter

SN	Name	Range	Default	Description
S01	Max speed	500~5000 (s/m)	See 7.5	Maximum speed.
S02	Min speed	150~500 (s/m)	150	Minimum speed.
S03	Speed of start tacking	500~2500 (s/m)	See 7.5	Speed of start tacking.
S04	Speed of end tacking	500~2500 (s/m)	See 7.5	Speed of end tacking.
S05	Speed of bar tacking sewing	500~2500 (s/m)	See 7.5	Speed of bar tacking sewing.
S06	Speed of C-S sewing	500~4500 (s/m)	See 7.5	Speed of constant-stitch sewing.
S07	Trimming speed	150~300 (s/m)	200	Speed of trimming.
S08	Slow sewing speed	200~500 (s/m)	400	Slow sewing speed when start.

9.2 Time parameter

SN	Name	Range	Default	Description
T01	RVS action time	1~200 (ms)	See 7.5	Action time of the REV SOL.
T02	RVS release time	1~200 (ms)	See 7.5	Release time of the REV SOL.
T03	Delay time of wiper	1~200 (ms)	20	Timing before the wiper solenoid act.
T04	Action time of wiper	1~200 (ms)	30	Timing for the wiper solenoid action.

T05	Delay time of foot lifter	1~500 (ms)	10	Timing before the foot lifter solenoid is act.
T06	Release time of foot lifter	1~500 (ms)	50	Timing before the foot lifter solenoid is released.
T07	Time of foot lifter whole output	1~999 (ms)	500	Timing of the foot lifter solenoid is act with whole output.
T08	Time of RVS whole output	1~999 (ms)	150	Timing of the reverse solenoid is act with whole output.
T10	Time of remove shake	1~500 (ms)	10	The speed controller will be greater sensitive when the value is smaller.

9.3 Enable parameter

SN	Name	Range	Default	Description
A01	Up position	ON~OFF	ON	ON: the stop position is up OFF: the stop position is down
A02	Automatically sewing	ON~OFF	ON	Valid only in constant-stitch sewing, when set to "ON", enable the automatic sewing.
A03	mode of stitch correction	ON~OFF	OFF	ON: continual OFF: half needle
A04	Stitch correction with single button	ON~OFF	OFF	For free sewing, if there is single switch on machine arms, when set to "OFF" the switch is reverse switch always. When set to "ON", the switch is reverse switch at sewing and is stitch correction switch at stop.
A05	Stitch correction with double button	ON~OFF	See 7.5	When set to "ON", enable the reverse and stitch correction switch both are valid. When set to "OFF", disable the double key be valid at the same time, and in this mode, the function of the single switch is determined by A04 .
A06	Trimming	ON~OFF	ON	When it is "ON", enable the trimming.
A07	Wiping	ON~OFF	ON	When it is "ON", enable the wiping.

				When A06 is “OFF”, A07 is invalid.
A08	Foot lift	ON~OFF	ON	When it is “ON”, enable foot lift. Whether the foot SOL to be connected is detected during power on automatically.
A09	clamp	ON~OFF	OFF	“ON” to enable clamp, only for GC6280.
A14	Trimming protection	ON~OFF	ON	When it is “ON”, the pedal must be back to the balance position to do next operation after trimming, “OFF” to be no required.
A15	Foot lift after trimming	ON~OFF	OFF	When A08 is “ON”, if A15 is set to “ON”, the foot lifter will lift automatically after trimming.
A16	The first segment keep on with the start tacking of C-S sewing	ON~OFF	ON	It is valid only for constant-stitch sewing. If enable automatic sewing mode and set the start tacking, the next segment of constant-stitch sewing will do automatically after the start tacking is finished when it is “ON”. When it is “OFF” or disable the automatic sewing mode, machine will stop automatically after the start tacking is finished.
A17	The end tacking keep on with the last segment of C-S sewing	ON~OFF	ON	It is valid only for constant-stitch sewing. If enable automatic sewing mode, the end tacking and trimming will do automatically after the last segment of constant-stitch sewing is finished when it is “ON”. When it is “OFF” or disable the automatic sewing mode, machine will stop automatically after the last segment of constant-stitch sewing is finished. The end tacking and trimming will do until step forward the pedal again.
A18	Move to up position after	ON~OFF	OFF	When it is “ON”, the machine will move to up position and stop automatically as

	power on			power on.
A19	Foot lifer acting in foot lift position	ON~OFF	ON	When the pedal is half back toe down, if it is "ON", the position is foot lift. If it is "OFF", the position is to be balance.
A20	Trimmer acting in foot lift position	ON~OFF	OFF	When it is "ON", the trimming will at the foot lifer position.
A21	Soft start	ON~OFF	OFF	When it is "ON", it will do a soft start after trimming.

9.4 Degree parameter (can be accessed by press **P** during power on)

SN	Name	Range	Default	Descriptions
D01	Up lever	0~359 (°)	60	Up lever degree.
D02	Down lever	0~359 (°)	215	Needle bar down degree.
D03	Trimmer act	0~359 (°)	250	Trimmer act degree.
D04	Trimmer release	0~359 (°)	0	Trimmer release degree.
D05	Reverse act	0~359 (°)	300	Reverse SOL. act degree.
D06	Reverse release	0~359 (°)	300	Reverse SOL. act release degree.
D07	Clamp act	0~359 (°)	180	Clamp act degree.
D08	Clamp release	0~359 (°)	270	Clamp release degree.
D09	Puller start	0~359 (°)	50	Puller starts degree per round.
D10	Puller end	0~359 (°)	120	Puller stops degree per round.

9.5 Special function parameter (can be accessed by press **P** during power on)

SN	Name	Range	Default	Descriptions
O01	Stitches of slow sewing at start	0~10 (needle)	3	The stitches of slow sewing at start when trimming is finished. The speed of slow sewing is set in S08 .
O03	Machine type	1~30	See 7.5	According to the machine type.
O05	Duty of foot lifter output	10~99 (%)	50	The duty cycle of PWM for signal of foot lifter solenoid. The power will be greater if this value is bigger, at the same time, the heat is more.
O06	Foot lifter release timed	ON~OFF	ON	When it is "ON", the foot lifter solenoid will be released automatically after the time desired.
O06	RVS release timed	ON~OFF	ON	When it is "ON", the RVS solenoid will be released automatically after the time desired.
O15	Parameter encrypt	ON~OFF	OFF	See 7.9.
O17	Initialization of parameters	ON~OFF	OFF	See 7.8.
O23	Running time of aging test	1~60(s)	5	The running time of aging test.
O24	Idle time of aging test	1~60(s)	5	The idle time of aging test.
O25	Total time of aging test	1~255 (h)	1	The total time of aging test. It will be stopped when reached the time.
O26	Aging test enable	ON~OFF	OFF	"ON" to active the aging test.
O27	User's password	0~9999	1234	See 7.9
O30	Identifier enable	ON~OFF	ON	See 7.5.
O31	Safety SW. enable	ON~OFF	See 7.5	"ON" to enable the safety switch function.
O32	Safety SW. mode	0~1	1	0: Normal close, 1: Normal open.

10. Measurement of Error and Warning

Error code	Causation	Measurement
E01	Voltage is too high	Check the AC power.
E02	Voltage is too low	Check the AC power.
E05	Break ineffective	Replace break resistor.
E08	Load is too heavy	Check the load.
E09	Speed controller error	Check speed controller, see 11.1.
E10	Position check error	Check synchronizer, see page 11.2.
E13	Machine type error	Check identifier, see 7.5.
E14	Trimmer SOL. error	Check SOL. whether direct short.
E15	REV SOL. error	Check SOL. whether direct short.
E16	Wiper SOL. error	Check SOL. whether direct short.
E17	Foot lifter SOL. error	Check SOL. whether direct short.
PEdL	Pedal warning	Release the pedal to balance position.
CArE	Safety SW warning	Check Safety SW., or set O32 to match the machine type.
3	Inspector disconnected warning	All automatic functions will be no effective.

11. Signal Checking

Press **S** during power on, it will display “TEST” and then enter the mode of Measurement of Input Signal. Bar A show the SN.

11.1 Speed controller



Display of the different pedal position as below:

Display code	Meanings	Descriptions
FS02~FS99	High speed	The second segment forward, pull is 02~99.
LS01	Low speed	The first segment forward, pull is 01.
BL--	Balance	Default.
FP--	Foot lifter	The first segment backward.
TM--	Trimming	The second segment of backward.

ERRO	Fault	Speed controller fault or disconnected.
------	-------	-----------------------------------------

11.2 Synchronizer



Bar D and E denote the up position, bar C and D denote the down position. Turn the hand wheel by hand equably, display of different position as below:

Display code	Meanings	Descriptions
UP--	Needle up position	In up position.
--DW	Needle down position	In down position.
----	Other position	Neither in up or down position.
ERRO	Fault	Both in up and down position.

11.3 Switch



E – REV. SW. F – COR. SW. G -- Safety SW.

11.4 Hall signal of motor



Turn the hand wheel by hand equably, display the hall signal of motor, range is 0~7. If the fault state appeared, then display “ERRO”.

11.5 Encoder signal of motor



Turn the hand wheel by hand equably, display the encode count of motor, the error is ± 5 normally.

11.6 Solenoid



Through **D+**, **D-**, **E+** and **E-** to select the SOL, use **G+** to test, as below:

Display code	SOL	Display code	SOL
TM	Trimmer SOL	RV	REV SOL
WP	Wiper SOL	FP	Foot Lifter SOL

11.7 Identifier



Display the code of identifier, see page 16. Display “ERRO” while fault.

11.8 Version of software



For example, the version is v 1.00.

11.9 AC power



Display the current AC power is 220V.

11.10 SOL. DC power



Display the current SOL. DC power is 31.2V.

11.11 Machine degree



First to setup zero point, use **C+** or **C-** to change degree type, turn hand wheel equably, display the current degree.

- Zero point (display “ZO”)

Turn hand wheel to top dead center, and then press **S** to set zero degree point.

- Up lever (display “UP”)

Turn hand wheel to up lever, press **S** to save current degree to up lever position. If display is equal to existent parameter, a twinkling “O” will be

displayed in bar D.

The setup of other degree parameters are same with above.

- Down lever (display “DW”)
- Trimmer act (display “TA”)
- Trimmer release (display “TR”)
- Reverse act (display “RA”)
- Reverse release (display “RR”)
- Clamp act (display “CA”)
- Clamp release (display “CR”)
- Puller start (display “PS”)
- Puller stop (display “PE”)

12. Review the History Errors

The system can save the error code automatically when error occurred.

Checking the history error by operation as below:

- ▲ Press **D+** during power on to access the history errors interface;













- ▲ Press **A+** and **A-** to check the 10 error code of recent, Display “NO” if there is no error;
- ▲ Bar C refer to the error index, bar D~G display the message, as below:



























Index	Message
A	Error code
B	AC power of the time
C	DC power of the time
F	Speed of the time
G	Year of the time, such as 2008
H	Date of the time, for example, 0804 indicate Aug. 4
I	Time of the time, for example, 1510 indicate 15:10

Appendix I: 7-segment Display Characters Compare Table

Arabic Number

Actual	0	1	2	3	4	5	6	7	8	9
Display										

English Alphabet

Actual	A	B	C	D	E	F	G	H	I	J
Display										
Actual	K	L	M	N	O	P	Q	R	S	T
Display										
Actual	U	V	W	X	Y	Z				
Display										

Appendix II: How to adjust the speed controller

If the magnet in speed controller has been replaced, or installation position of PCB has been changed, new adjustment should be performed.

Each position showed as below:

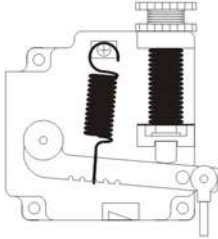

Balance position

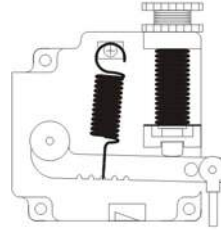

Foot lifter position

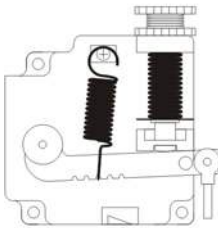

Farthest position backward

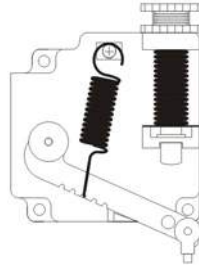

Farthest position forward

Steps of adjustment showed as below:

- Push the switch on PCB of speed controller during the power on;
- Release the switch, after setting the speed controller to balance position, press the switch once;
- After setting the speed controller to the farthest position forward, press the switch once again;
- After setting the speed controller to the foot lifter position, press the switch once again;
- After setting the speed controller to the farthest position backward, press the switch once again;
- After all, the adjustment is accomplished, all function would be normal after power on again.

Appendix III: How to update the control box with the update module

User could update software of control box by update module if necessary, the operations showed as below:

- Turn off the power, plug the update module into identifier socket , then power on again;
- The error code “E 23” would be displayed if not matching;
- “UM xxx” would be displayed if matching, and xxx denote version of update module;
- Press **S** to start update procedure, it will be accomplished after “UM ok” displayed. All procedure will take in half minute. Then Turn off the power and plug the identifier, all function would be normal after power on again.

Add: No.1 Taibai South Road,
Xi'an, P.R.China-710068

Tel: +86-29-88279162 88279163

Fax: 029-88279161 83911111

E-mail: typical@chinatypical.com

[Http://www.chinatypical.com](http://www.chinatypical.com)

V3